

Dual Power Supply
PSD3203

User Manual

scientific

Copyright © Scientific All rights reserved.

This instrument contains proprietary information, no part of this manual may be photocopied, reproduced or translated without any prior written consent.

Information in this manual supercede all corresponding previous released material.

Scientific continues to improve products and reserves rights to amend part or all of the specifications, procedures, equipment at any time without notice.

Rev 1.3 / 0514



Scientific Mes-Technik Pvt. Ltd.,

B-14 Industrial Estate, Pologround,
Indore 452015(India)

Tel : 0731-2422330/31/32/33

Fax : 0731-2422334,561641

Email : info@scientificindia.com

Dual Power Supply PSD3203

Table of Contents

1.	Introduction	4
2.	Technical Specifications	5
3.	Front Panel Controls.....	6
4.	Operating Instructions.....	8
	General Information.....	8
	Safety.....	8
	Operating Conditions	8
	First Time Operation.....	9
	Operation	9
6.	Maintenance	12
	Power Line Fuse Replacement	12
7.	Dispatch Procedure for Service.....	13
8.	Warranty Conditions.....	14
9.	List of Service Centers.....	16

Dual Power Supply

PSD3203

- Floating DC supply voltages
- 2 x DC 0 – 30 V, 0 – 3 A
- Constant voltage and constant current operation
- Digital display for voltage and current
- Adjustable current limiter
- Protection against overload and short circuit

The **PSD3203** 30 V , 3 A Dual Power supply is designed as a constant **current (CC) and constant voltage (CV)**, source for laboratories, industries and field testing applications, featuring low power loss, compact and light weight. It provides two isolated and floated, DC output voltages and is ideally suitable for complex analog and digital testing.

The DC output can be continuously adjusted from 0 to 30 V with coarse and fine controls. Current limit is also adjustable up to 3 A. Any over loading for adjusted current limit is indicated by "CC" LED. When the maximum setting is crossed or the overheating has occurred, the LED will lit.

A 3 digit display for voltage and current switchable for the power supply A & B, is used to read the instantaneous values. These two parameters are switchable for indicating either voltage or current. In addition to low residual ripple and noise as well as excellent line and load regulation, the **PSD3203** is provided with all protective circuits to ensure trouble free operation.

Technical Specifications

DC Outputs	: A: 0 - 30 V, 3A B: 0 - 30 V, 3A continuously variable by means of coarse and fine controls
Output Current	: 3 A (Max.)
Setting Resolution	: Voltage : 10 mV Current : 5 mA
Internal Resistance	: $\leq 10 \text{ m}\Omega$
Stability	: $\leq 2.5 \text{ mV}$ at 30 V, 5 A
Recovery Time	: $\leq 50 \text{ }\mu\text{s}$
Load Regulation	: $\leq \pm (0.05\% + 10 \text{ mV})$
Line Regulation	: $\leq \pm (0.05\% + 10 \text{ mV})$
Temperature Coefficient	: $\leq \pm (0.05\% + 10 \text{ mV}/^\circ\text{C})$
Ripple and Noise	: $\leq 1 \text{ mVrms}$
Current Limit	: Adjustable between 100 mA to 3 A
Display	: 3 digit for voltage and current
Accuracy	: $\pm (1\% + 1\text{digit})$
Over range Indication	: By lighting 'CC' LED.

General Information :

	Built-in overheat, over voltage, overload protection.
Insulation	: Between chassis and output $> 10 \text{ M}\Omega$ at 100 V dc : Between chassis and AC plug $> 50 \text{ M}\Omega$ at 500 V dc
Power Supply	: 230 V $\pm 10\%$, 50 – 60 Hz (100/ 120/ 220/ 240 V available on request)
Operating Condition	: 0 - 40 $^\circ\text{C}$, 95 % RH
Dimension	: W 165 , H 215 , D 360 mm
Weight	: 7.5 kgs. Approx.

(Subject to change)

Front Panel Controls

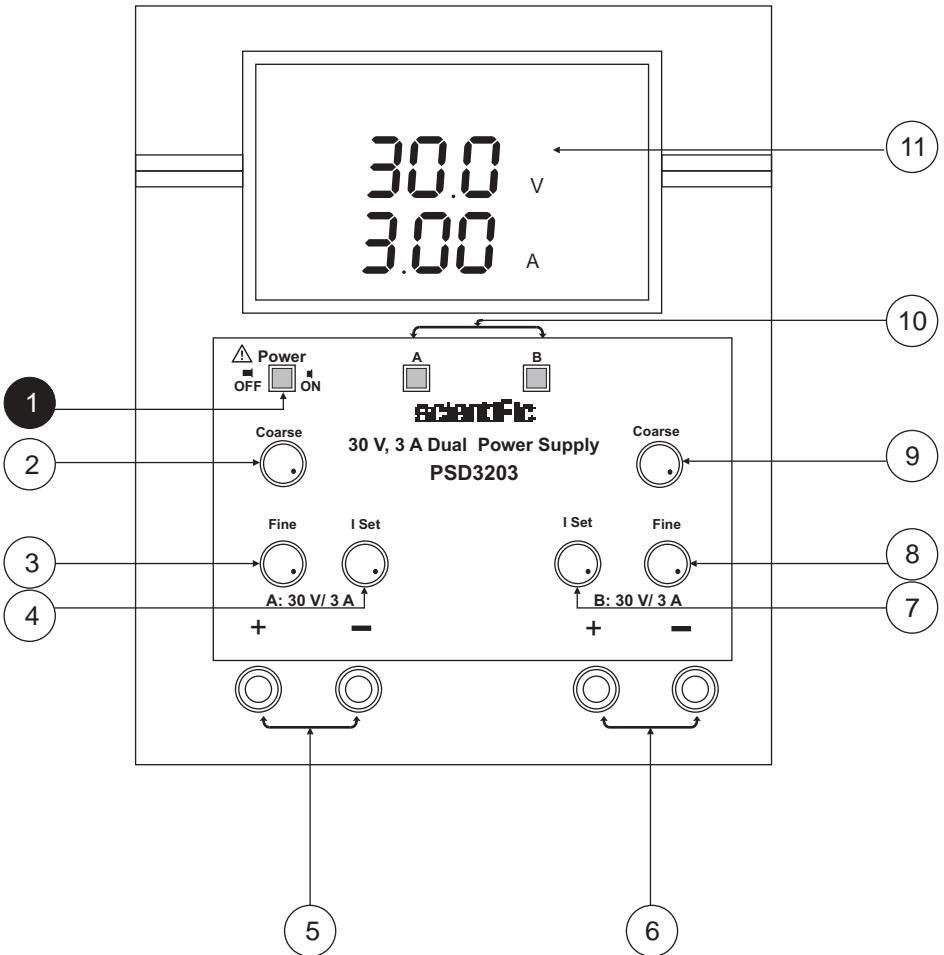

- ❶ **POWER:** Push button for Switching ON/OFF the 230 V mains supply to the instrument.

- ❷ & ❸ **Coarse** (VARIABLE POTENTIOMETER): Variable potentiometer for the coarse setting of the output voltages from the output terminals A & B. Adjustment range 0-30 V.

- ❹ & ❺ **Fine** (VARIABLE POTENTIOMETER): Variable potentiometer for the fine setting of the output voltage at terminals. Adjustment range 2.1 V.

- ❻ **I_{Set}** (VARIABLE POTENTIOMETER): Variable potentiometer for current limit setting of the voltage source. Adjustment range 0.1 A - 3.00A.

- ❼ & ❽ **Outputs :** Output terminals for DC Power Supply “A” & “B” . Output terminals of 4 mm-banana plugs for cable connection. The Output is short circuit protected.

- ❿ **Push Buttons A, B:** Push buttons are used to switch display from power supply A to B & vice versa. Voltage & current reading are simultaneously displayed for power supply A or B depending up on switch selected. Current is displayed with resolution of 10 mA & voltage with resolution of 0.01 V.

- ⓫ **Display Window:** Individual display for voltage & current of power supply A or B depending up on switch selected.

When supply “A” is in constant current mode the “A” LED lits. When supply “A” is in constant current mode the “B” LED lits.

Note: The instrument is provided with over voltage protection from mains variation. The over voltage setting is at 253 V , whenever , the mains increases beyond the set voltage , it trips and LED “HV” is lit. After the mains normalized, switch OFF once the instrument and then switch ON again , if the mains is below 253 V, the instrument get switched ON , other wise trips again.

Operating Instructions

General Information

The logical front panel layout of **PSD3203** ensures rapid familiarization with the various functions. However, even experienced operators should not neglect to carefully read the following instructions, to avoid any operational errors and to be fully acquainted with the instrument when later in use.

After unpacking the instrument, check for any mechanical damage or loose parts inside. Should there be any transportation damage, inform the supplier immediately and do not put the instrument into operation.

Safety

The case chassis and all measuring parts are connected to the protective earth contact of the inlet. The mains plug shall only be inserted in a socket outlet provided with a protective earth contact. The protective action must not be negated by the use of an extension cord without a protective conductor.

Warning!

Any interruption of the protective conductor inside or outside the instrument or disconnection of the protective earth terminal is likely to make the instrument dangerous. Intentional interruption is prohibited. The mains/line plug should be inserted before connections are made to measuring circuits.

When removing the metal case or replacing, the instrument must be completely disconnected from the mains supply. If any measurement or calibration procedures are unavoidable on the opened-up instrument, these must only be carried out by qualified personnel acquainted with the danger involved.

Operating Conditions

The ambient temperature range during operation should be between $+0^{\circ}$ to $+40^{\circ}\text{C}$ and should not exceed -40°C or $+70^{\circ}\text{C}$ during transport or storage. The operational position is optional, however, the ventilation holes on the **PSD3203** must not be obstructed. Prior to calibration a preheat run of approx. 30 minutes is required.

First Time Operation

After unpacking the instrument check for any mechanical damages. The instrument should be plugged in mains-plug of proper mains supply $230\text{ V} \pm 10\%$. On switch ON no undue observation should be noticed. Once the instrument is switched ON the power ON is indicated by lighting of displays.

Operation

The power supply has an electrically floating output. This permits easy series or parallel connection with other power supply units, to increase supply voltage or current respectively.

PSD3203 Dual Fixed Output voltage operation :

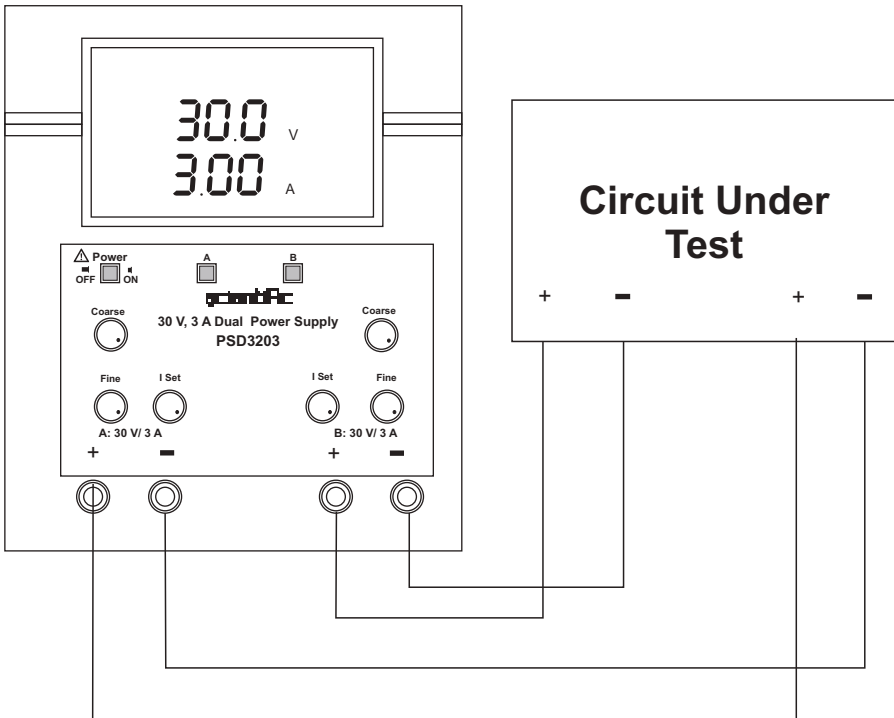

Setting for +V & -V Outputs

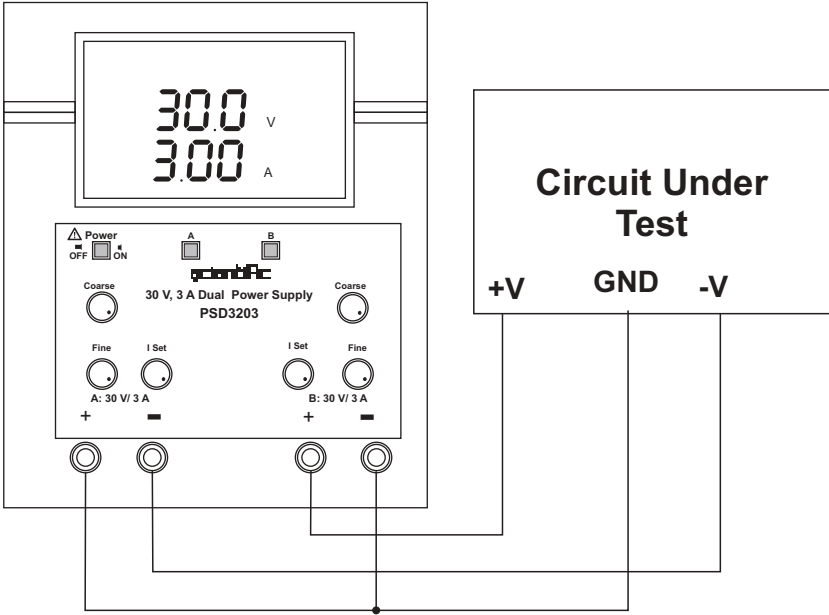

Serial operation for 60 V, 3 A

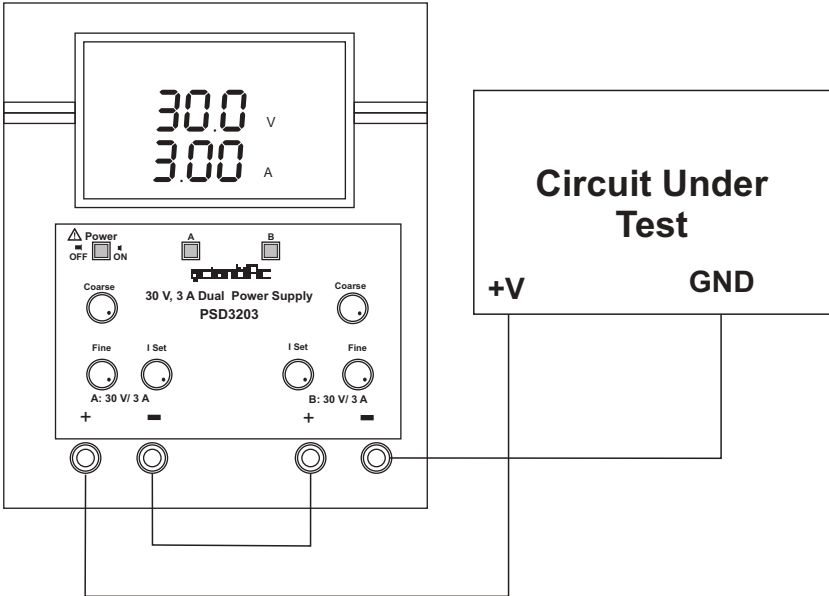

Parallel Operation for 30 V, 6 A

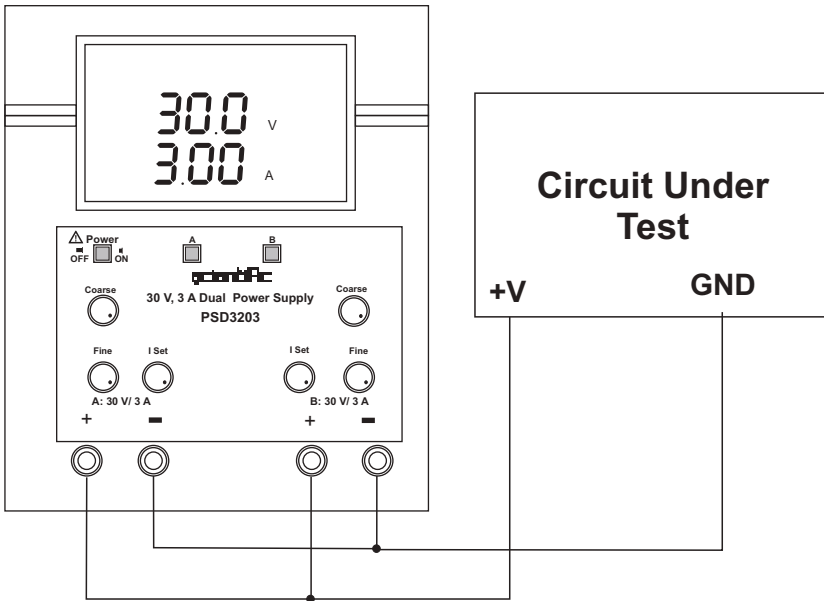

Over Voltage Protection

The instrument is provided with over voltage protection from mains variation. The over voltage setting is at 253 V, whenever, the mains increases beyond the set voltage, it trips and LED "HV" is lit. After the mains normalized, switch OFF once the instrument and then switch ON again, if the mains is below 253 V, the instrument get switched ON, other wise trips again.

Maintenance

There are no user serviceable part inside **PSD3203**.Your **PSD3203** 30 V, 3 A Dual Power Supply is thoughtfully engineered for ease of use, accuracy and reliability. The instrument is carefully tested and calibrated using standards traceable to National Laboratories.

Take care of your instrument by cleaning the exterior of the instrument regularly with a dusting brush. Dirt which is difficult to remove on the casing & plastic parts, can be removed with a moist cloth (99% water, 1% mild detergent) spirit or washing benzene (petroleum ether) can be used to remove greasy dirt. The display may be cleaned with water or washing benzene (but not with spirit-alcohol solvents), it must then be wiped with a dry clean lint-free cloth. Under no circumstances the cleaning fluid should get into the instrument. The use of cleaning agents can attack the plastic & paint surfaces.

Power Line Fuse Replacement

The power line fuse is located on rear panel on lower right side. In case, the instrument does not show any sign of working, no LED is lit or there is no display immediately switch OFF the mains power switch of the instrument and unplug the mains cord from the mains socket. With the help of small flat blade screwdriver remove the fuse cap of the fuse holder, located just below the socket. There is one spare fuse kept in the fuse cap, replace it for the defective one. Press the cap so that it locks in place . The rating of the fuse is 4 A, 250 V , slow blow , 5x20 mm glass fuse. Do not use a fuse with a higher value other wise it may damage the instrument in case, the mains voltage goes much higher than the rating of the mains fluctuation of $\pm 10\%$.

Dispatch Procedure For Service

No user serviceable parts are inside the instrument , should it become necessary to send back the instrument to factory for service, please observe the following procedure.

Before dispatching the instrument please write to us giving full details of the fault noticed.

1. After receipt of your communication, our service department. will advise you whether it is necessary to send the instrument back to us for repairs or the adjustment is possible in your premises.
2. Dispatch the instrument (only on the receipt of our advise) securely packed in original packing duly insured and freight paid along with accessories and a copy of the faults details noticed at our Service Center listed on last page of this manual, nearest to you.

Warranty Conditions

1. Scientific warrants all its Instruments to be free from defects in material and workmanship when used under normal operating conditions in accordance with the instructions given in the manual for a period of 12 (Twelve) months from date of purchase from Scientific or its authorised dealers. The service during the warranty period will be rendered on return to factory /service center basis.
2. Its obligation under this warranty is limited to repairing or replacing at its own discretion. This warranty shall not apply to any defect, failure or damage caused by accident, negligence, mis-application, alteration or attempt to repair, service or modify in any way.
3. This warranty does not include LED, fuses, batteries or accessories. This warranty is only valid with the original purchaser who must have properly registered the product within 15 days from date of purchase. No other warranty is expressed or implied.
4. When it becomes necessary to return the instrument to our Factory facility, kindly pack it carefully in the original carton or equivalent and ship it duly insured, transportation charges prepaid.
5. Your Scientific instrument is a complex electronic device and deserves the best service available by technicians thoroughly familiar with its service and calibration procedures.

Notes

Major Service Centers

Phone / Fax / Email

1. Scientific Mes-Technik Pvt. Ltd.,
92, Electronics Complex,
Pardeshipura,
Indore M. P. 452 010
Ph : (0731) 2309741,2422330-31
Fax :(0731)2422334, 2561641
info@scientificindia.com
2. Scientific Mes-Technik Pvt. Ltd.,
B-13, D.S.I.D.C Packging Complex
Kirti Nagar, New Delhil 110 015
Ph : (011) 65638100, 65638101
Fax:(011)26536298
ndelhi@scientificindia.com
3. Scientific Mes-Technik Pvt. Ltd.,
NO. 46, 4th Main Cross ,
MLA Layout,
R. T. Nagar, Bangaluru 560 032
Ph : (080) 23437635
Fax:(080)23331478
bangalore@scientificindia.com
4. Scientific Mes-Technik Pvt. Ltd.,
No. 25 , 2 nd floor,
29 th Cross Street
Indira Nagar, Adyar
Chennai 600 020
Ph : (044) 24424598
Fax :(044) 24420421
chennai@scientificindia.com
5. Scientific Mes-Technik Pvt. Ltd.,
Room No. 308, Building No.2,
3rd Floor, Sundar Nagar
Co-op. Hsg Society Ltd.
Senapati Bapat Marg, Dadar (W)
Mumbai 400 028
Ph. :(022) 24211171
Fax :(022)24333654
mumbai@scientificindia.com
6. Scientific Mes-Technik Pvt. Ltd.,
209, Lloyd's Chamber III
409, Mangalwar Peth,
Maldhakka Chowk ,
Pune 411 011
Ph. : (020)26114688
Fax : (020)26132882
pune@scientificindia.com
7. Scientific Mes-Technik Pvt. Ltd.,
"Krupa Ashirwad Complex",
2nd Floor, Door No.5-2-394 81/A,
R.P. Road, Hyderbasti
Secunderabad 500026
Ph : (040)27534995
Fax : (040)27534996
hyderabad@scientificindia.com
8. Scientific Mes-Technik Pvt. Ltd.,
2, Chowringhee Road,
Kolkata 700 013
Ph : (033) 2228 2223-6
Fax : (033)2228 1713
kolkata@scientificindia.com